



Eric H. Castain
Senior Vice President
Business Object Services

March 2001

Wells Fargo Environment

- Large number of mainframe based Systems of Record (SOR's) which are based on CICS, COBOL, DB/2, IMS, etc.
- Client applications are Win/NT or Unix based systems using object technology
- High processing volumes with tight constraints on response time and availability commitments
- Used CORBA middleware to bridge the two processing environments while meeting the service level requirements

Processing Environment

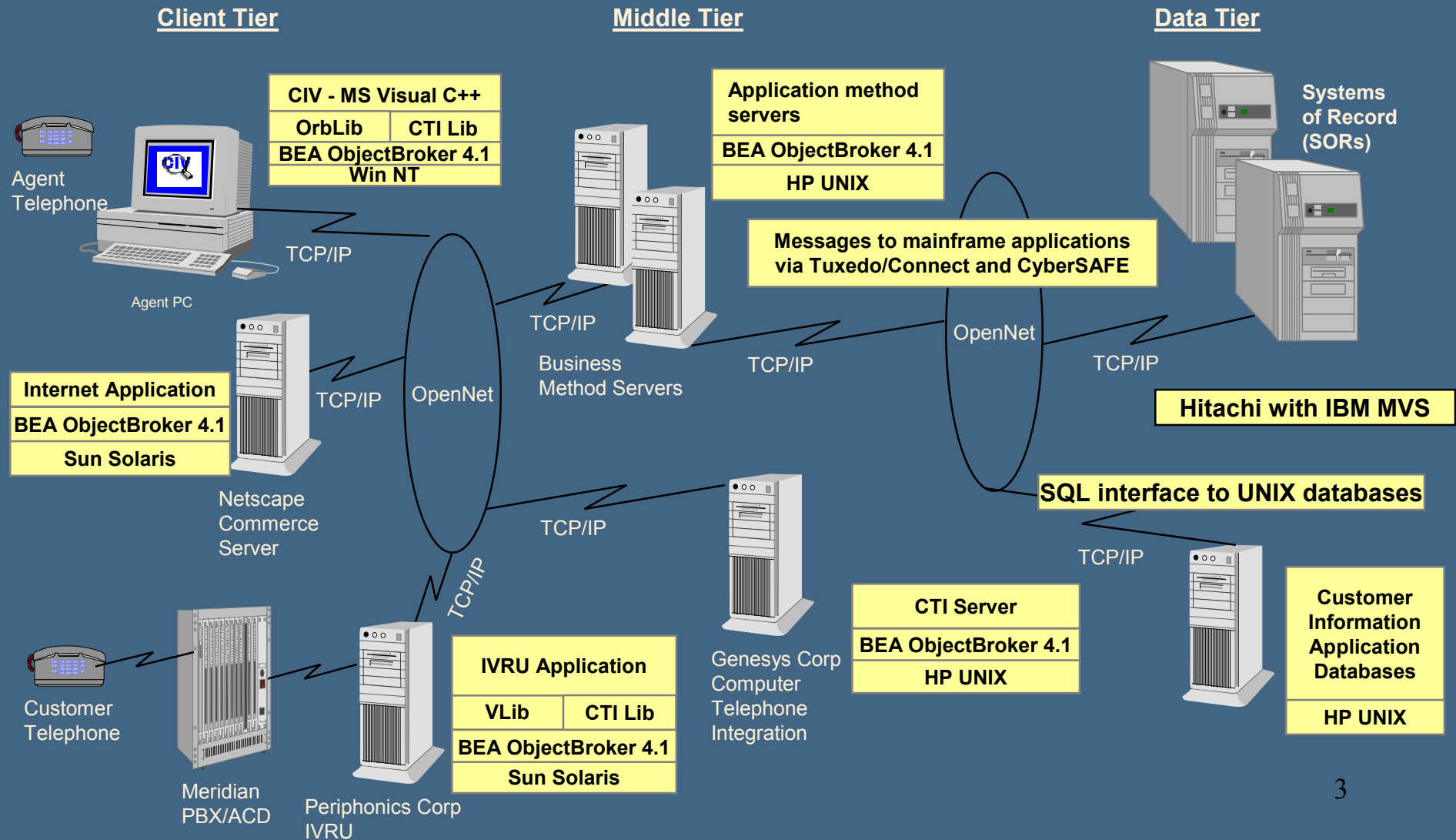

Wells Frame

- An object based framework that normalizes the disparate SOR's present in the enterprise into a consistent, standard environment or logical system.
- Provides a single interface to the client application business analyst and programmer.
- The framework is both platform and language neutral.

Application Development Steps

- Define the application in a platform independent model in UML
- Generate the appropriate UML platform specific models needed by the application
- Augment the model with any additional code needed by the application that completes the business logic functionality
- Generate the application programs

Implementing from a model

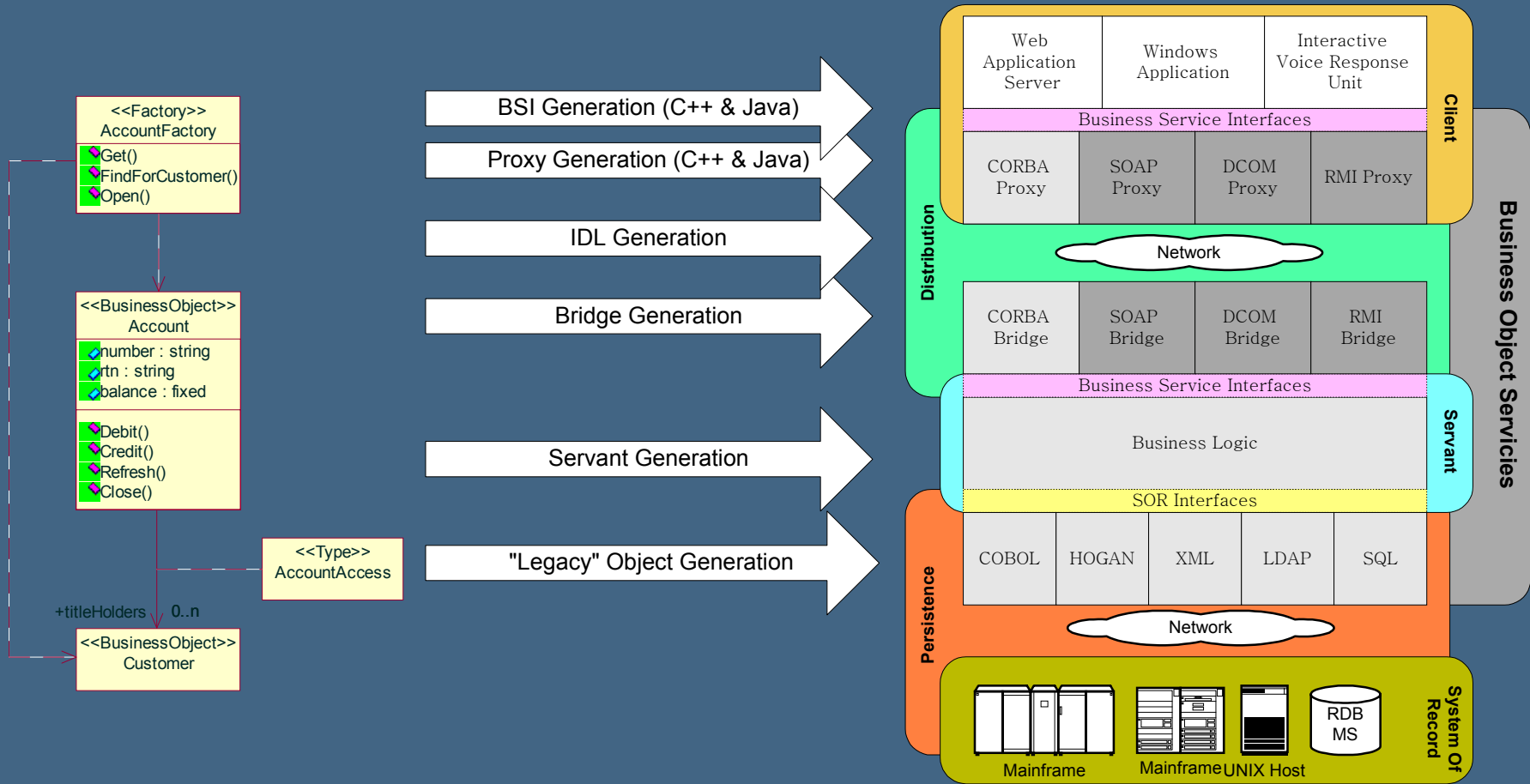

Summary

- Architecture based on platform independent models is allowing us
 - to effectively support additional new functionality
 - while migrating a large application to a newer version of CORBA
 - and also allowing us to support additional languages such as Java
- We believe the OMG's Model Driven Architecture is a validation of Wells Fargo's direction in an open industry standard forum that will greatly benefit us in the future